

OWNERS MANUAL



Intended to alert the user to the presence of uninsulated "dangerous voltage" within the product's enclosure that may be of sufficient magnitude to constitute a risk of electric shock to persons.



Intended to alert the user to the presence of important operating and maintenance (servicing) instructions in the literature accompanying the product.

CAUTION: Risks of electrical shock — DO NOT OPEN

CAUTION: To reduce the risk of electric shock, do not remove cover. No user serviceable parts inside. Refer Servicing to qualified service personnel.



Revolution™



WARNING: TO PREVENT ELECTRICAL SHOCK OR FIRE HAZARD, DO NOT EXPOSE THIS APPLIANCE TO RAIN OR MOISTURE. BEFORE USING THIS APPLIANCE, READ THE OPERATING GUIDE FOR FURTHER WARNINGS.

REVOLUTION™

18

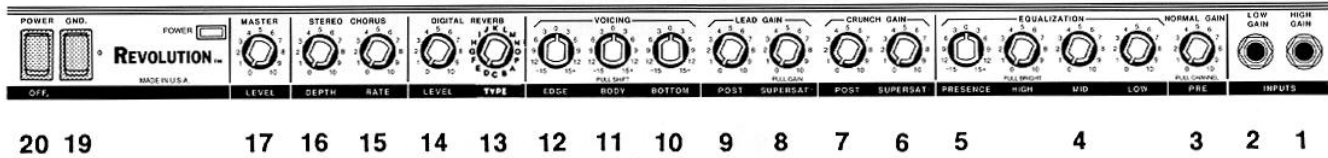

HIGH GAIN INPUT (1)

Used for most electric guitars. It is 6 dB louder than the Low Gain input.

LOW GAIN INPUT (2)

Provided for instruments that have extremely high outputs, which can result in overdriving (distorting) the High Gain input. If both inputs are used simultaneously, the output levels are the same (both are Low Gain).

NORMAL GAIN/PULL CHANNEL SELECT (3)

Controls the volume level of the Normal channel and is not affected by the SuperSat® or Post Gain controls. The Normal Gain control is also a "push-pull" channel select switch. The "in" position selects the Normal channel and the "out" position selects the Crunch/Lead channels.

NOTE: When controlling channel selection from the supplied remote footswitch, the Channel Select switch must be in the "out" position.

LOW, MID, AND HIGH EQ (HIGH/PULL BRIGHT) (4)

Passive tone controls that regulate the low, mid, and high frequencies respectively. The High EQ control is also a "push-pull" bright switch. The "Out" position provides a preset boost (+6 dB) to treble frequencies. The "In" position defeats the bright boost.

PRESENCE (ACTIVE) (5)

An active tone control (± 15 dB) that varies the extreme high frequency range. 0 to +15 boost (increase), 0 to -15 cut (reduce).

SUPERSAT® (6)

A transistor simulation of tube distortion (soft clipping). To activate the SuperSat effect, Crunch channel must be activated via remote footswitch.

POST GAIN (7)

Controls the overall volume level of the Crunch channel. The final level adjustment should be made after the desired sound has been achieved.

SUPERSAT®/PULL GAIN (8)

A transistor simulation of tube distortion (soft clipping). To activate the SuperSat effect, Lead channel must be activated. The SuperSat control is also a "push-pull" gain switch. The "out" position boosts the overall system gain. Push "in" to defeat gain boost.

POST GAIN (9)

Controls the overall volume level of the Lead channel. The final level adjustment should be made after the desired sound has been achieved.

BOTTOM (10)

An active tone control (shelving type ± 15 dB) that varies the low frequency boost or cut.

NOTE: This control is not functional on the Normal channel.

BODY/PULL SHIFT (11)

An active tone control (peak/notch ± 15 dB) that varies the mid frequency boost or cut. The Body control is also a "push-pull" shift switch. The "out" position of this control allows the Body control to function at a higher frequency and the "in" position selects a lower frequency.

NOTE: This control is not functional on the Normal channel.

EDGE (12)

An active tone control (shelving type, ± 15 dB) that varies the high frequency boost or cut.

NOTE: This control is not functional on the Normal channel.

REVERB SELECT (13)

Set this control to the desired digital reverb, echo, or delay. (See effect table)

NOTE: For optional reverb footswitch selection, Reverb Select must be set to "K".

LEVEL (14)

Determines the level of the digital effects processor. This control works in conjunction with the effect select switch (type).

RATE CONTROL (15)

Controls the sweep rate (frequency) of the chorus effect.

DEPTH CONTROL (16)

Controls the depth (intensity) of the chorus effect.

MASTER LEVEL CONTROL (17)

Controls the overall volume level of the system.

POWER LED (18)

Illuminates when AC power is being supplied to the amp.

GROUND SWITCH (19)

Three position rocker-type switch which, in most applications, should be operated in its center or zero position. There may be some situations when audible hum and/or noise will come from the loudspeaker. If this situation arises, position the ground switch to either positive or negative (+ or -) or until the noise is minimized.

NOTE: Should the noise problem continue, consult your Authorized Peavey Dealer, the Peavey Factory, or a qualified service technician. THE GROUND SWITCH IS NOT FUNCTIONAL ON 220/240 VOLT MODELS.

POWER SWITCH (20)

Depress the switch to the "On" position. The red pilot light (LED) will illuminate indicating power is being supplied to the unit.



POWER AMP INPUT (21)

Use to connect line level signal to the power amplifier.

PREAMP OUT MIX 2 (22)

The Preamp Output can be used to route the amplified signal to a mixing console, tape recorder, etc. Connect the Preamp Output, using a shielded cable, to an input of the tape recorder, mixer, outboard power amplifier, etc. This patch does not affect the operation of the amplifier.

NOTE: When only the preamp out mix 2 jack is used, the mixed chorus effect is present at this point. (Combination of dry and chorused signals) When both preamp out jacks are engaged, only the chorused signal appears at this point.

PREAMP OUT DRY 1 (23)

The preamp output can be used to route the amplified signal to a mixing console, tape recorder, etc. Connect the preamp output, using a shielded cable, to an input of the tape recorder, mixer, outboard power amplifier, etc. This patch does not affect the operation of the amplifier.

NOTE: The dry (unchorused) signal is always present at this point even when both preamp out jacks are engaged. This jack should be used for normal preamp out patching when the chorus effect is not desired.

REMOTE FOOTSWITCH JACK (24)

Provides for the connection of the supplied remote. Footswitch is used to select the Normal, Crunch, or Lead channels and defeat the digital reverb and chorus circuits.

NOTE: The footswitch is equipped with LEDs to indicate channel and effects have been selected.

LINE CORD (120V PRODUCTS ONLY) (25)

For your safety, we have incorporated a 3-wire line (mains) cable with proper grounding facilities. It is not advisable to remove the ground pin under any circumstances. If it is necessary to use the equipment without proper grounding facilities, suitable grounding adaptors should be used. Less noise and greatly reduced shock hazard exists when the unit is operated with the proper grounded receptacles.

OPTIONAL REVERB FOOTSWITCH JACK (26)

The 6-pin jack is used for the "optional" reverb footswitch. This special function footswitch has the capability to change the digital reverb presets remotely.

The Digital Reverb Remote Switch is an optional accessory that allows the user to change the Digital Reverb "Type" setting from a remote location. The footswitch has two LED readouts, two increment buttons, and a select button to choose between the two settings chosen with the increment buttons. For correct footswitch operation, the Reverb "TYPE" control on the amplifier must be set to the "K" position.



SPEAKER OUTPUTS (27)

Provided for connection of external speaker(s). Minimum total impedance is 4 ohms.

IMPEDANCE SELECTOR SWITCH (28)

Use to select the appropriate impedance of the speaker(s). For example, if two speakers of equal impedance are used, the switch should be set to one-half of that value. If two 16 ohm cabinets are used, the impedance selector should be set to 8 ohms.

REVOLUTION™ ENGINEERING SPECIFICATIONS

POWER AMPLIFIER SECTION

Rated Power & Load: (Each channel)

150W RMS into 16, 8, or 4 ohms/separately
130W RMS into 16, 8, or 4 ohms/both channels driven (260W RMS total)

Power @ Clipping: (Typical each channel)

(5% THD, 1 kHz, 120V AC line)
140W RMS into 16, 8, or 4 ohms/both channels driven

Frequency Response:

+0, -1 dB, 60 Hz to 15 kHz,
@ 100W RMS into 16, 8, or 4 ohms

Total Harmonic Distortion:

Less than 0.6%, 100 mW to 100W RMS, 60 Hz to 15 kHz, 16, 8, or 4 ohms

Hum & Noise:

Greater than 90 dB below rated power

Power Consumption:

500W, 50/60 Hz, 120V AC

PREAMP SECTION

The following specs are measured @

1 kHz with the controls preset as follows:

Push Bright Off (In)
Low & High @ 10; Mid @ 0
Presence @ 0 dB
SuperSat® & Post Gain (Crunch) @ 10
SuperSat® & Post Gain (Lead) @ 10
Pull Gain On (Out)
Bottom, Body, & Edge @ 0 dB
Pull Shift Off (In)
Digital Reverb level @ 0
Chorus Rate & Depth @ 0
Master Level @ 10

Nominal levels are with input gain @ 5

Minimum levels are with input gain @ 10

Preamp High Gain Input: (Normal channel)

Impedance: High Z, 220K ohms
Nominal Input Level: -16 dBV, 150mV RMS
Minimum Input Level: -34 dBV, 20 mV RMS
Maximum Input Level: +16 dBV, 6V RMS

Preamp Low Gain Input: (Normal channel)

Impedance: High Z, 44K ohms
Nominal Input Level: -10 dBV, 300 mV RMS
Minimum Input Level: -40 dBV, 10 mV RMS

Preamp High Gain Input: (Lead channel)

Impedance: High Z, 220K ohms
Nominal Input Level: -68 dBV, .4 mV RMS
Minimum Input Level: -76 dBV, .15 mV RMS

Preamp Output 1: (Dry signal, no chorus)

Load Impedance: 1K ohms or greater
Nominal Output Level: 0 dBV, 1V RMS
(Switching jack, removes dry signal feed to output #2 when used, allowing full stereo output patching)

Preamp Output 2: (Mix of dry and chorus signals)

Load Impedance: 1k ohms or greater
Nominal Output: 0 dBV, 1V RMS
(This output is converted to chorus signal only, if output #1 above is used for output patching)

Power Amp Input/Each Channel:

Impedance: High Z, 20K ohms
Designed Input Level: 0 dBV, 1V RMS
(Switching jack providing Preamp Out to Power Amp Input connection when not used)

System Hum & Noise @ Nominal Input Level:

(20 Hz to 20 kHz unweighted)
80 dB below rated power

Equalization: (Normal Channel Only)

Special Low, Mid & High passive type EQ
Pull Bright: +6 dB @ 2 kHz
Presence: ±15 dB @ 5 kHz, active shelving

Voicing: (Crunch & Lead Channels Only)

Special Bottom, Body, & Edge active type EQ
Pull Shift: Shifts Body voicing effect
Pull Gain: Increases SuperSat® lead gain

Remote Footswitch Function:

Reverb defeat (when reverb control is raised)
Chorus Defeat (when chorus depth is raised)
Crunch/Lead Bypass (when selected with pull switch)
Crunch or Lead Channel Select (when not bypassed)

Reverb Remote Footswitch Function: (Optional)

Digital Reverb Select (when reverb control is raised)
(Front panel type control must be set to K position)

EFFECT TABLE

EFFECT PRESET	REVERB TIME	ROOM SIZE	TONALITY
A	0.5 SEC	SMALL	WARM
B	1.2 SEC	SMALL	WARM
C	2.8 SEC	SMALL	WARM
D	2.5 SEC	LARGE	BRIGHT
E	2.0 SEC	MEDIUM	BRIGHT
F	2.4 SEC	MEDIUM	WARM
G	3.8 SEC	MEDIUM	WARM

EFFECT TABLE

H	4.0 SEC	LARGE	WARM
I	20 SEC	LARGE	DARK
EFFECT PRESET		EFFECT TIME	TIME
J	GATED REVERB		400 MSEC
K	DELAY EFFECT		LEFT 40 MSEC, RIGHT 65 MSEC
L	DELAY EFFECT		LEFT 75 MSEC, RIGHT 90 MSEC
M	DELAY EFFECT		LEFT 125 MSEC, RIGHT 140 MSEC
N	ECHO W/FEEDBACK OF ¼		LEFT 200 MSEC, RIGHT 225 MSEC
O	ECHO W/FEEDBACK OF ¼		LEFT 300 MSEC, RIGHT 325 MSEC
P	ECHOED REVERB		300 MSEC

TONE SETTING CHART

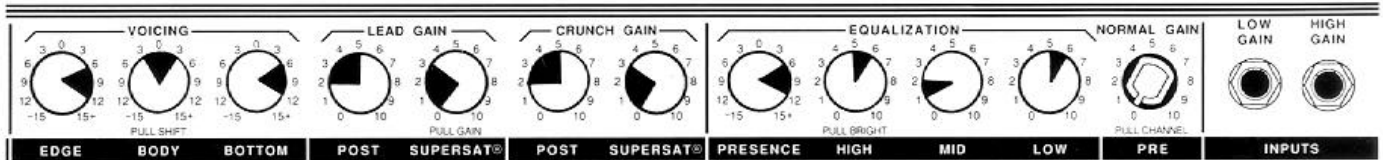

"IN"

"IN"

"OUT"

ADJUST
TO TASTE

COUNTRY LEAD

COUNTRY-CLEAN

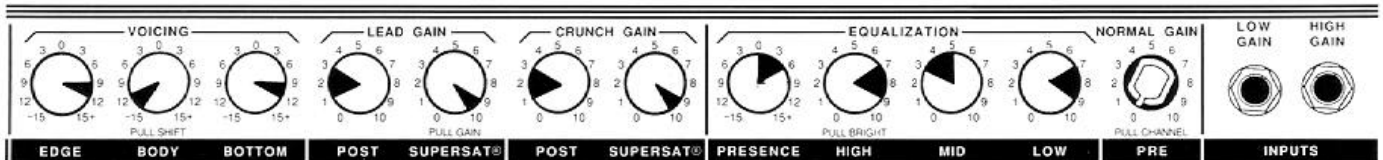

"OUT"

"OUT"

"OUT"

ADJUST
TO TASTE

METAL

CLEAN

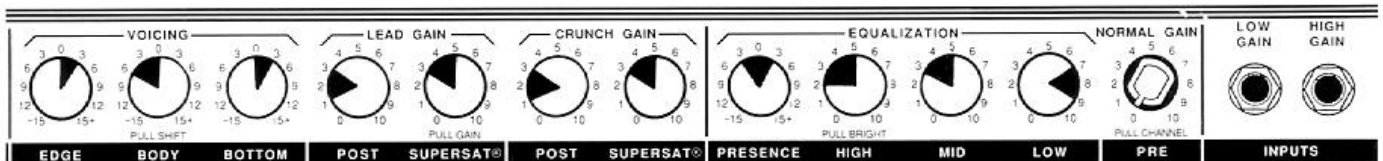

"IN"

"IN"

"IN"

ADJUST
TO TASTE

MEDIUM
DISTORTION

JAZZ

Block Diagram

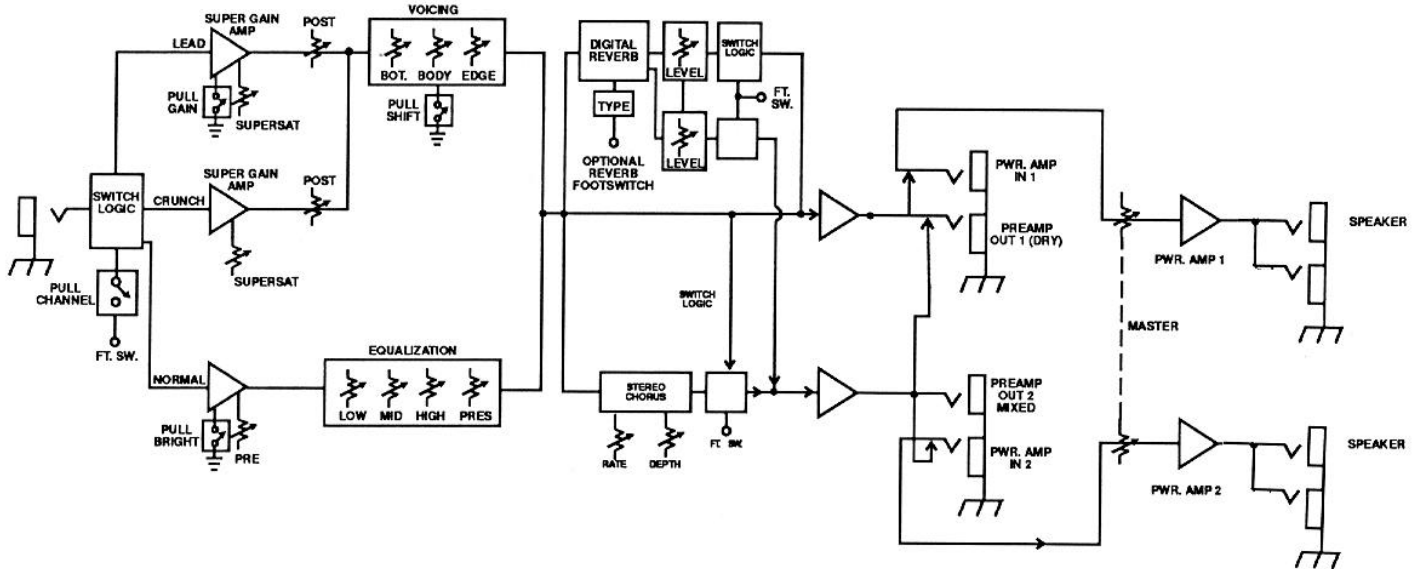

DANGER
EXPOSURE TO EXTREMELY HIGH NOISE LEVELS MAY CAUSE A PERMANENT HEARING LOSS. INDIVIDUALS VARY CONSIDERABLY IN SUSCEPTIBILITY TO NOISE INDUCED HEARING LOSS, BUT NEARLY EVERYONE WILL LOSE SOME HEARING IF EXPOSED TO SUFFICIENTLY INTENSE NOISE FOR A SUFFICIENT TIME.

THE U.S. GOVERNMENT'S OCCUPATIONAL SAFETY AND HEALTH ADMINISTRATION (OSHA) HAS SPECIFIED THE FOLLOWING PERMISSIBLE NOISE LEVEL EXPOSURES:

DURATION PER DAY IN HOURS	SOUND LEVEL dBA, SLOW RESPONSE
8	90
6	92
4	95
3	97
2	100
1½	102
1	105
¾	110
½ or less	115

ACCORDING TO OSHA, ANY EXPOSURE IN EXCESS OF THE ABOVE PERMISSIBLE LIMITS COULD RESULT IN SOME HEARING LOSS.

EAR PLUGS OR PROTECTORS IN THE EAR CANALS OR OVER THE EARS MUST BE WORN WHEN OPERATING THIS AMPLIFICATION SYSTEM IN ORDER TO PREVENT A PERMANENT HEARING LOSS IF EXPOSURE IS IN EXCESS OF THE LIMITS AS SET FORTH ABOVE. TO INSURE AGAINST POTENTIALLY DANGEROUS EXPOSURE TO HIGH SOUND PRESSURE LEVELS, IT IS RECOMMENDED THAT ALL PERSONS EXPOSED TO EQUIPMENT CAPABLE OF PRODUCING HIGH SOUND PRESSURE LEVELS SUCH AS THIS AMPLIFICATION SYSTEM BE PROTECTED BY HEARING PROTECTORS WHILE THIS UNIT IS IN OPERATION.

CAUTION
THIS AMPLIFIER HAS BEEN DESIGNED AND CONSTRUCTED TO PROVIDE ADEQUATE POWER RESERVE FOR PLAYING MODERN MUSIC WHICH MAY REQUIRE OCCASIONAL PEAK POWER TO HANDLE OCCASIONAL PEAK POWER. ADEQUATE POWER "HEADROOM" HAS BEEN DESIGNED INTO THIS SYSTEM. EXTENDED OPERATION AT ABSOLUTE MAXIMUM POWER LEVELS IS NOT RECOMMENDED SINCE THIS COULD DAMAGE THE ASSOCIATED LOUSPEAKER SYSTEM. PLEASE BE AWARE THAT **MAXIMUM POWER** CAN BE OBTAINED WITH VERY LOW SETTINGS OF THE **GAIN** CONTROLS IF THE INPUT SIGNAL IS VERY STRONG.

- Read all safety and operating instructions before using this product.
- All safety and operating instructions should be retained for future reference.
- Obey all cautions in the operating instructions and on the back of the unit.
- All operating instructions should be followed.
- This product should not be used near water, i.e. a bathtub, sink, swimming pool, wet basement, etc.
- This product should be located so that its position does not interfere with its proper ventilation. It should not be placed flat against a wall or placed in a built-in enclosure that will impede the flow of cooling air.
- This product should not be placed near a source of heat such as a stove, radiator or another heat producing amplifier.
- Connect only to a power supply of the type marked on the unit adjacent to the power supply cord.
- Never break off the ground pin on the power supply cord. For more information on grounding write for our free booklet "Shock Hazard and Grounding."
- Power supply cords should always be handled carefully. Never walk or place equipment on power supply cords. Periodically check cords for cuts or signs of stress, especially at the plug and the point where the cord exits the unit.
- The power supply cord should be unplugged when the unit is to be unused for long periods of time.
- If this product is to be mounted in an equipment rack, rear support should be provided.
- Metal parts can be cleaned with a damp rag. The vinyl covering used on some units can be cleaned with a damp rag or an ammonia based household cleaner if necessary.
- Care should be taken so that objects do not fall and liquids are not spilled into the unit through the ventilation holes or any other openings.
- This unit should be checked by a qualified service technician if:
 - The power supply cord or plug has been damaged.
 - Anything has fallen or been spilled into the unit.
 - The unit does not operate correctly.
 - The unit has been dropped or the enclosure damaged.
- The user should not attempt to service this equipment. All service work should be done by a qualified service technician.

THIS LIMITED WARRANTY VALID ONLY WHEN PURCHASED AND REGISTERED IN THE UNITED STATES OR CANADA. ALL EXPORTED PRODUCTS ARE SUBJECT TO WARRANTY AND SERVICES TO BE SPECIFIED AND PROVIDED BY THE AUTHORIZED DISTRIBUTOR FOR EACH COUNTRY.

Ces clauses de garantie ne sont valables qu'aux Etats-Unis et au Canada. Dans tout les autres pays, les clauses de garantie et de maintenance sont fixees par le distributeur national et assuree par lui seion la legislation envigueur.

Diese Garantie ist nur in den USA und Kanada gultig. Alle Export-Produkte sind der Garantie und dem Service des Importeurs des jewelligen Landes unterworfen. Esta garantia es valida solamente cuando el producto es comprado en E.U. continentales o en Canada. Todos los productos que sean comprados en el extranjero, estan sujetos a las garantias y servicio que cada distribuidor autorizado determine y ofrezca en los diferentes paises.

**PEAVEY ONE-YEAR LIMITED
WARRANTY/REMEDY**

PEAVEY ELECTRONICS CORPORATION ("PEAVEY") warrants this product, EXCEPT for covers, footswitches, patchcords, tubes and meters, to be free from defects in material and workmanship for a period of one (1) year from date of purchase, PROVIDED, however, that this limited warranty is extended only to the original retail purchaser and is subject to the conditions, exclusions, and limitations hereinafter set forth:

PEAVEY 90-DAY LIMITED WARRANTY ON TUBES AND METERS

If this product contains tubes or meters, Peavey warrants the tubes or meters contained in the product to be free from defects in material and workmanship for a period of ninety (90) days from date of purchase; PROVIDED, however, that this limited warranty is extended only to the original retail purchaser and is also subject to the conditions, exclusions, and limitations hereinafter set forth.

CONDITIONS, EXCLUSIONS, AND LIMITATIONS OF LIMITED WARRANTIES

These limited warranties shall be void and of no effect, if:

- a. The first purchase of the product is for the purpose of resale; or
- b. The original retail purchase is not made from an AUTHORIZED PEAVEY DEALER; or
- c. The product has been damaged by accident or unreasonable use, neglect, improper service or maintenance, or other causes not arising out of defects in material or workmanship; or
- d. The serial number affixed to the product is altered, defaced, or removed.

In the event of a defect in material and/or workmanship covered by this limited warranty, Peavey will:

- a. In the case of tubes or meters, replace the defective component without charge.
- b. In other covered cases (i.e., cases involving anything other than covers, footswitches, patchcords, tubes or meters), repair the defect in material or workmanship or replace the product, at Peavey's option; and provided, however, that, in any case, all costs of shipping, if necessary, are paid by you, the purchaser.

THE WARRANTY REGISTRATION CARD SHOULD BE ACCURATELY COMPLETED AND MAILED TO AND RECEIVED BY PEAVEY WITHIN FOURTEEN (14) DAYS FROM THE DATE OF YOUR PURCHASE.

In order to obtain service under these warranties, you must:

- a. Bring the defective item to any PEAVEY AUTHORIZED DEALER or AUTHORIZED PEAVEY SERVICE CENTER and present therewith the ORIGINAL PROOF OF PURCHASE supplied to you by the AUTHORIZED PEAVEY DEALER in connection with your purchase from him of this product. If the DEALER or SERVICE CENTER is unable to provide the necessary warranty service you will be directed to the nearest other PEAVEY AUTHORIZED DEALER or AUTHORIZED PEAVEY SERVICE CENTER which can provide such service.

OR

- b. Ship the defective item, prepaid, to:

PEAVEY ELECTRONICS CORPORATION
International Service Center
Highway 80 East
MERIDIAN, MS 39301

including therewith a complete, detailed description of the problem, together with a legible copy of the original PROOF OF PURCHASE and a complete return address. Upon Peavey's receipt of these items:

If the defect is remedial under these limited warranties and the other terms and conditions expressed herein have been complied with, Peavey will provide the necessary warranty service to repair or replace the product and will return it, FREIGHT COLLECT, to you, the purchaser.

Peavey's liability to the purchaser for damages from any cause whatsoever and regardless of the form of action, including negligence, is limited to the actual damages up to the greater of \$500.00 or an amount equal to the purchase price of the product that caused the damage or that is the subject of or is directly related to the cause of action. Such purchase price will be that in effect for the specific product when the cause of action arose. This limitation of liability will not apply to claims for personal injury or damage to real property or tangible personal property allegedly caused by Peavey's negligence. Peavey does not assume liability for personal injury or property damage arising out of or caused by a non-Peavey alteration or attachment, nor does Peavey assume any responsibility for damage to interconnected non-Peavey equipment that may result from the normal functioning and maintenance of the Peavey equipment.

UNDER NO CIRCUMSTANCES WILL PEAVEY BE LIABLE FOR ANY LOST PROFITS, LOST SAVINGS, ANY INCIDENTAL DAMAGES, OR ANY CONSEQUENTIAL DAMAGES ARISING OUT OF THE USE OR INABILITY TO USE THE PRODUCT, EVEN IF PEAVEY HAS BEEN ADVISED OF THE POSSIBILITY OF SUCH DAMAGES.

THESE LIMITED WARRANTIES ARE IN LIEU OF ANY AND ALL WARRANTIES, EXPRESSED OR IMPLIED, INCLUDING, BUT NOT LIMITED TO, THE IMPLIED WARRANTIES OF MERCHANTABILITY AND FITNESS FOR A PARTICULAR USE; PROVIDED, HOWEVER, THAT IF THE OTHER TERMS AND CONDITIONS NECESSARY TO THE EXISTENCE OF THE EXPRESSED, LIMITED WARRANTIES, AS HEREINABOVE STATED, HAVE BEEN COMPLIED WITH, IMPLIED WARRANTIES ARE NOT DISCLAIMED DURING THE APPLICABLE ONE-YEAR OR NINETY-DAY PERIOD FROM DATE OF PURCHASE OF THIS PRODUCT.

SOME STATES DO NOT ALLOW LIMITATION ON HOW LONG AN IMPLIED WARRANTY LASTS, OR THE EXCLUSION OR LIMITATION OF INCIDENTAL OR CONSEQUENTIAL DAMAGES, SO THE ABOVE LIMITATIONS OR EXCLUSIONS MAY NOT APPLY TO YOU. THESE LIMITED WARRANTIES GIVE YOU SPECIFIC LEGAL RIGHTS, AND YOU MAY ALSO HAVE OTHER RIGHTS WHICH MAY VARY FROM STATE TO STATE.

THESE LIMITED WARRANTIES ARE THE ONLY EXPRESSED WARRANTIES ON THIS PRODUCT, AND NO OTHER STATEMENT, REPRESENTATION, WARRANTY, OR AGREEMENT BY ANY PERSON SHALL BE VALID OR BINDING UPON PEAVEY.

In the event of any modification or disclaimer of expressed or implied warranties, or any limitation of remedies, contained herein conflicts with applicable law, then such modification, disclaimer or limitation, as the case may be, shall be deemed to be modified to the extent necessary to comply with such law.

Your remedies for breach of these warranties are limited to those remedies provided herein and Peavey Electronics Corporation gives this limited warranty only with respect to equipment purchased in the United States of America.

INSTRUCTIONS — WARRANTY REGISTRATION CARD

1. Mail the completed WARRANTY REGISTRATION CARD to:

PEAVEY ELECTRONICS CORPORATION
POST OFFICE BOX 2898
MERIDIAN, MISSISSIPPI 39302-2898

- a. Keep the PROOF OF PURCHASE. In the event warranty service is required during the warranty period, you will need this document. **There will be no identification card issued by Peavey Electronics Corporation.**
2. IMPORTANCE OF WARRANTY REGISTRATION CARDS AND NOTIFICATION OF CHANGES OF ADDRESSES:
 - a. Completion and mailing of WARRANTY REGISTRATION CARDS — Should notification become necessary for any condition that may require correction, the REGISTRATION CARD will help ensure that you are contacted and properly notified.
 - b. Notice of address changes — If you move from the address shown on the WARRANTY REGISTRATION CARD, you should notify Peavey of the change of address so as to facilitate your receipt of any bulletins or other forms of notification which may become necessary in connection with any condition that may require dissemination of information or correction.
3. You may contact Peavey directly by telephoning (601) 483-5365.



Features and specifications subject to change without notice.

Peavey Electronics Corporation 711 A Street / Meridian, MS 39302-2898 / U.S.A. / (601) 483-5365 / Telex 504115 / Fax 484-4278
#80390037

©1991

Printed in U.S.A. 12/91