

SPECIFICATIONS

VCM™3

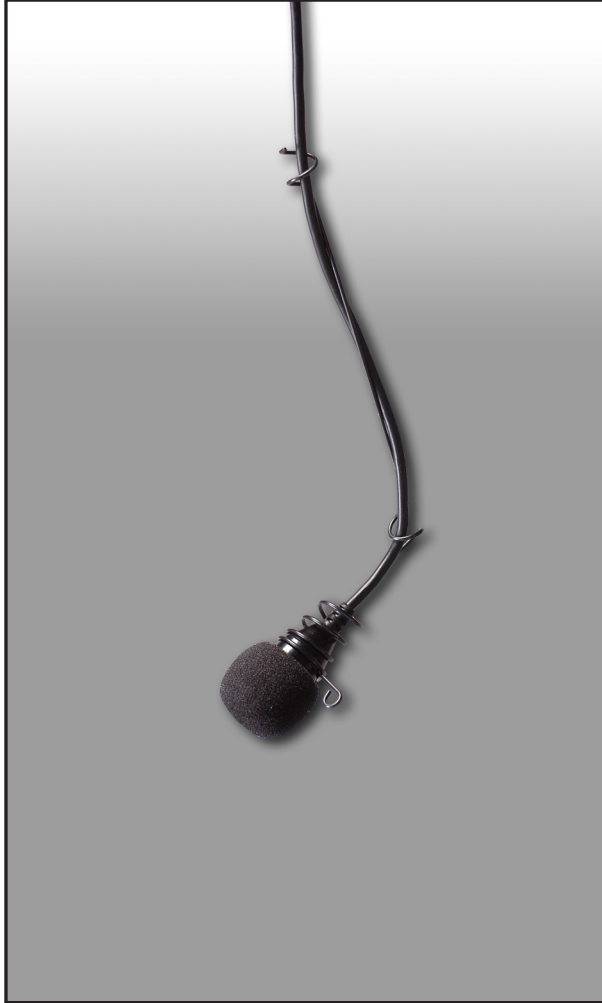

S/N ratio:
69 dB

Dynamic range:
115 dB

Power supply:
9~52V

Current consumption:
3 mA

Connector:
Mini three-pin XLR (QG)
connector

Dimensions:
Top diameter 0.47" (12
mm) x 33' (10m) cable

Net weight:
4.59 oz. (130 g)

Description

The VCM 3 is a low-profile microphone designed primarily to be suspended above choirs, ensembles or stage areas for sound reinforcement with virtually no visual distraction.

The back-electret condenser capsule offers a smooth, tailored frequency response with a cardioid pickup pattern that is highly effective in suppressing feedback and unwanted noise.

The hanging adapter is a flexible, steel-spring wire used to facilitate positioning of the VCM 3 when suspended by its cable.

The VCM 3 comes with a 33' (10 m) small-diameter cable, allowing it to remain as inconspicuous as possible. This rugged, durable cable will fully support the VCM 3 and its hanging adapter.

This cable connects to a compact output module. The output module also adapts the smaller QG-type connector to the typical three-pin XLR for use with a standard microphone cable. This adapter operates on phantom power supply DC voltages between 9 – 52 volts.

Type:

Back-electret condenser
microphone

Pickup pattern:

Cardioid

Frequency response:

50 Hz to 20 kHz

Sensitivity:

-45 dB/Pa

Rated impedance:

250 Ohms

Minimum load impedance:

1k Ohms

Maximum SPL:

140 dB

Features:

- Extremely small profile
- Back-electret condenser element
- Cardioid pickup pattern
- Smooth, wide-range frequency response
- 33' miniature cable for long drops
- Flexible, steel-spring wire hanging adapter
- Operational from 9 to 52 VDC phantom power source



CHOOSING POSITION

When hanging one or more VCM 3 mics above a choir or instrumental ensemble, the specific positioning for the optimum sound quality, balance and feedback control depends on many factors. The size and nature of the performers, the configuration of the performing area, the room in which the performance is taking place and the sound system characteristics are important considerations.

Usually the microphone is suspended somewhat above and in front (downstage) of the front row of performers. The VCM 3 is usually aimed to point slightly above the nearest performers.

If the ensemble is large enough to require more than one microphone, the "3-to-1" rule should be implemented. This simply means that, to achieve the best overall sound quality, the spacing between adjacent microphones should be three times the distance than that of the nearest performers.

The flexible hanging adapter should be used when suspending the VCM 3, but it may be removed for other applications if desired. When replacing the hanging adapter, wrap the microphone cable into the hanger's steel spirals and snap the element into the adapter. The VCM 3 can also be easily concealed in onstage props when desired.

ARCHITECTURAL & ENGINEERING SPECIFICATIONS

The microphone shall be back-electret, condenser type with a frequency response of 50 Hz to 20 kHz. The microphone shall have a cardioid response pattern with a rear response that is typically -20 dB from the front response. The microphone shall have an output level of -45 dBV/pascal and a nominal impedance of 250 Ohms. The microphone shall have a low gloss finish. Microphone element dimensions shall be 0.47" (12 mm) in diameter and 1.06" (27 mm) long with a attached cable of 33' (10 m) with a diameter of

0.10" (2.54 mm). The cable shall be terminated with a miniature three-pin connector to interface with the output module's electronics package. The output module shall have a low gloss-black finish and shall be 0.825" (20.96 mm) in diameter and 4.2" (106.68 mm) in length. The output module shall properly interface the microphone with any 9 to 52 Volt phantom power supply. A flexible, steel-spring hanging adapter shall be included for proper hanging of the microphone. The microphone shall be a Peavey VCM 3.

2 YEAR LIMITED WARRANTY

NOTE: For details, refer to the warranty statement. For copies of this statement, contact Peavey Electronics Corporation, at P.O. Box 2898, Meridian, Mississippi 39301-2898, or go online to www.peavey.com.



SPECIFICATIONS

VCM™₃

Pickup Patterns

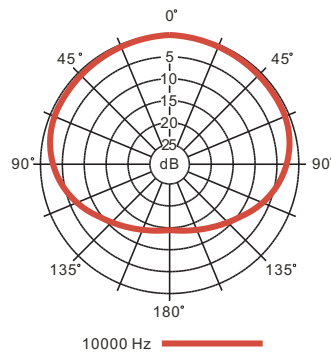
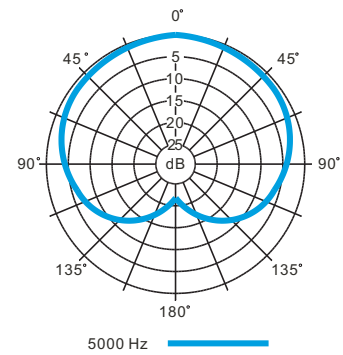
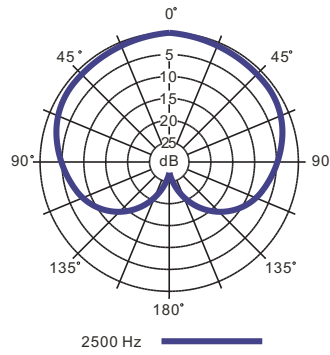
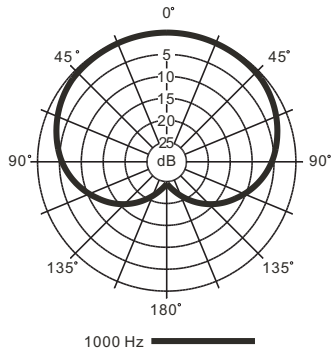
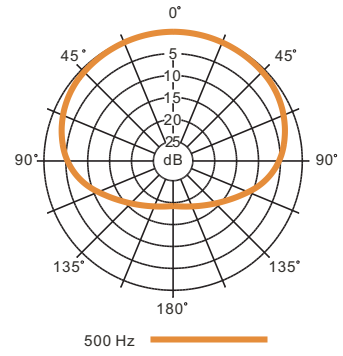
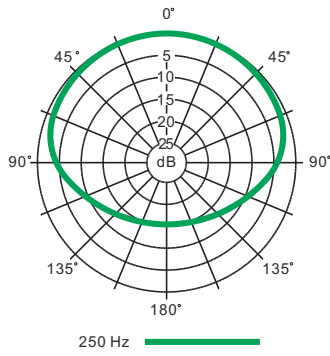
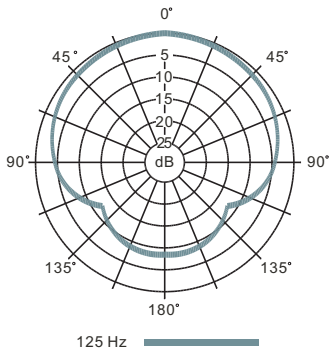

Frequency Response

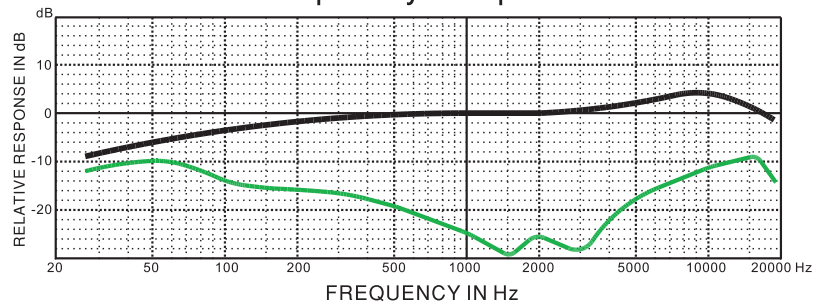



Features and specifications subject to change without notice.

Peavey Electronics Corporation • 5022 Hartley Peavey Drive • Meridian, MS 39305
(601) 483-5365 • FAX (601) 486-1278 • www.peavey.com

EX 000003